



# Standard Test Method for Determining Atmospheric Chloride Deposition Rate by Wet Candle Method<sup>1</sup>

This standard is issued under the fixed designation G140; the number immediately following the designation indicates the year of original adoption or, in the case of revision, the year of last revision. A number in parentheses indicates the year of last reapproval. A superscript epsilon ( $\epsilon$ ) indicates an editorial change since the last revision or reapproval.

## 1. Scope

1.1 This test method covers a wet candle device and its use in measuring atmospheric chloride deposition (amount of chloride salts deposited from the atmosphere on a given area per unit time).

1.2 Data on atmospheric chloride deposition can be useful in classifying the corrosivity of a specific area, such as an atmospheric test site. Caution must be exercised, however, to take into consideration the season because airborne chlorides vary widely between seasons.

1.3 *This standard does not purport to address all of the safety concerns, if any, associated with its use. It is the responsibility of the user of this standard to establish appropriate safety and health practices and determine the applicability of regulatory limitations prior to use.*

## 2. Referenced Documents

2.1 *ASTM Standards:*<sup>2</sup>

[D1193 Specification for Reagent Water](#)

[D4458 Test Method for Chloride Ions in Brackish Water, Seawater, and Brines](#)

[G92 Practice for Characterization of Atmospheric Test Sites](#)

2.2 *ISO Standard:*

[ISO 9225 Corrosion of Metals and Alloys. Aggressivity of Atmospheres—Methods of Measurement of Pollution Data](#)<sup>3</sup>

## 3. Significance and Use

3.1 This test method is capable of generating quantitative values of atmospheric chloride deposition specifying milli-

<sup>1</sup> This test method is under the jurisdiction of ASTM Committee G01 on Corrosion of Metals and is the direct responsibility of Subcommittee G01.04 on Atmospheric Corrosion.

Current edition approved Nov. 1, 2014. Published November 2014. Originally approved in 1996. Last previous edition approved in 2008 as G140–02 (2008). DOI: 10.1520/G0140-02R14.

<sup>2</sup> For referenced ASTM standards, visit the ASTM website, [www.astm.org](http://www.astm.org), or contact ASTM Customer Service at [service@astm.org](mailto:service@astm.org). For *Annual Book of ASTM Standards* volume information, refer to the standard's Document Summary page on the ASTM website.

<sup>3</sup> Available from American National Standards Institute (ANSI), 25 W. 43rd St., 4th Floor, New York, NY 10036, <http://www.ansi.org>.

grams of chloride ions per square metre per day (or other units derived from such values).

NOTE 1—Chlorides in the atmosphere exist as a suspension of liquid droplets or solid particles. They are transported to solid surfaces by gravity, wind, or brownian motions. These transport mechanisms are direction-sensitive so that a vertical cylinder will not necessarily receive the same flux as a horizontal plate, or objects with different sizes and orientations. Therefore, the use of this approach to provide an indication of the deposition of chlorides on objects in atmospheric exposures may not be quantitatively accurate; however, this technique has been successful in classifying the severity of exposure in a variety of marine locations.

3.2 The sites where samples are to be taken and the sampling time periods should be established. A continuous program of monthly or 30-day exposures is recommended for site characterization. Seasonal monitoring may be performed if there are specific periods of interest.

## 4. Apparatus

4.1 *Components*—The components needed to construct one wet candle device are as follows:

4.1.1 *Erlenmeyer Flask*, narrow mouth, 500 mL, (glass or polypropylene). Other size flasks may be used, but dimensions in [Fig. 1](#) will have to be adjusted accordingly.

NOTE 2—Polypropylene flasks are recommended during threat of freezing weather.

4.1.2 *Glass Test Tube*, general purpose, 16 by 150-mm length.

4.1.3 *Solid Rubber or Neoprene Stopper*, No. 7, diameter top 38 mm, bottom 30 mm.

4.1.4 *Cotton Bandage Gauze*, strip, 50 mm wide and approximately 1500 mm long.

NOTE 3—The overall length of the gauze may vary with installation.

4.1.5 *Type IV Reagent Water*, 1 L, 200 mL CHOH (CH<sub>2</sub>OH<sub>2</sub>) (glycerin) and 20 drops CH<sub>3</sub>(CH<sub>2</sub>)<sub>6</sub>COOH (octanoic acid) should be added to prevent freezing, if necessary (See Specification [D1193](#)).

4.1.6 *Gloves*, vinyl, one pair.

NOTE 4—Poly(vinyl chloride) (PVC) is recommended. Latex gloves are not acceptable, as their chloride content is reported to be comparable to that of human hands.

4.2 *Support Stand*—A suitable support stand shall be erected at the site where the atmosphere is to be sampled. A treated

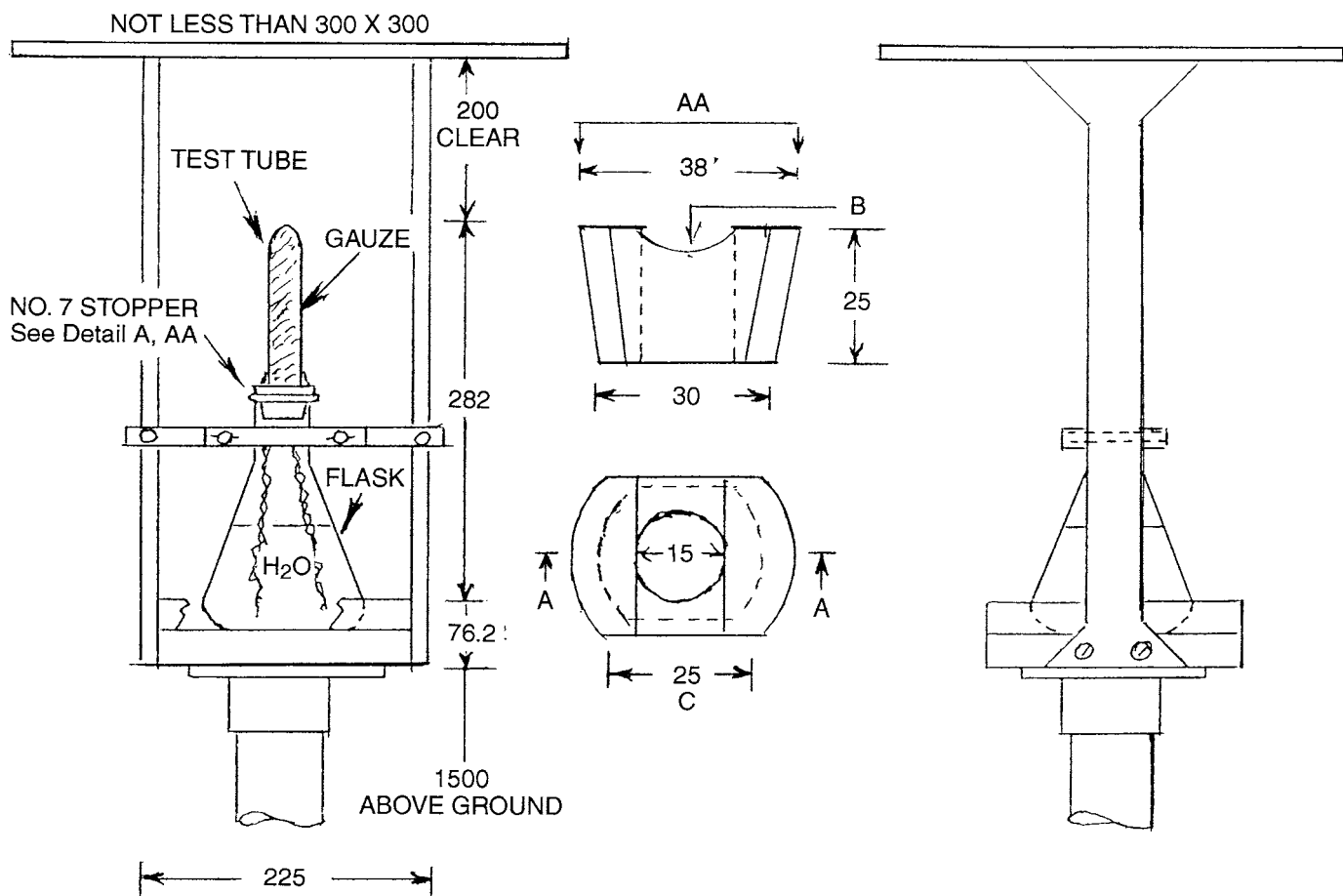

NOTE 1—Dimensions are in millimetres (mm).

FIG. 1 Wet Candle Chloride Apparatus

wood post (100 by 100 by 2250 mm) or galvanized pipe (42-mm diameter by 2250-mm length) with an attached plate on top is suitable, with 750 mm in the ground and 1500 mm above the ground on which the apparatus to hold the candle can be mounted (see Fig. 1). The apparatus shall be mounted so that the arms supporting the rain cover do not shield the gauze from a known source of chloride.

4.3 Assembly of the Wet Candle Apparatus (see Fig. 1):

4.3.1 The rubber stopper must be modified.

4.3.1.1 In the center, bore a hole 15 mm in diameter through the stopper.

4.3.1.2 On opposite sides of the conical surface of the stopper, cut or grind a channel or flat, from top to bottom, sufficiently wide (~25 mm) for the gauze to pass freely between the stopper and the neck of the flask when the stopper is installed tightly in the flask (see Fig. 1).

4.3.2 Insert the test tube upward through the hole in the rubber stopper so that the lip of the tube is at the bottom of the small end of the stopper.

4.3.2.1 The flask and tube/stopper assembly should be rinsed with Type IV reagent water to remove any contaminants.

4.3.3 Cover bare hands with gloves (PVC or other plastic (see Note 4). With freshly opened bandage gauze (50 mm wide), start with a wick 150 mm in length, pass through one channel in the stopper and tightly wrap all the exposed area of

the tube. Using overlapping turns, move up the tube covering the top, then back down the tube to the stopper, pass the gauze through the other channel in the stopper, leaving another section of the gauze approximately equal in length to the first (150 mm).

NOTE 5—The total area of exposed gauze will be approximately 0.01 m<sup>2</sup>.

4.3.4 Rinse gauze with Type IV reagent water and fill the flask with 350 mL of Type IV reagent water (see 4.1.5).

4.3.5 Insert wick ends of gauze into flask and press stopper/tube assembly firmly into flask.

4.3.6 Care while handling and transporting candles is of utmost importance to prevent contamination by perspiration or other means. It is good practice to cover the assembled candle, either before or after filling the flask, with a protective shield to prevent accidental contamination during storage and transport, and also following retrieval for analysis. A polyethylene bag approximately 75 mm (3 in.) by 230 mm (9 in.) or plastic wrap has been found satisfactory. If a bag is used, it can be secured to the flask with a rubber band.

5. Procedure

5.1 Exposure of Wet Candle:

5.1.1 Place a wetted candle in the support stand. Remove the protective shield, and if not previously filled, handling the